

Montageanleitung (Original)

Mounting instructions

Instructions de montage

Die Montage und Wartung ist grundsätzlich nur von autorisiertem Fachpersonal vorzunehmen. Für die Installation und für den Betrieb dieser Leuchte sind die nationalen Sicherheitsvorschriften zu beachten. Der Hersteller übernimmt keine Haftung für Schäden, die durch unsachgemäßen Einsatz oder Montage entstehen. Werden nachträglich Änderungen an der Leuchte vorgenommen, so gilt derjenige als Hersteller, der diese Änderung vornimmt.

Mounting and maintenance must be performed by qualified personnel. The installation and operation of this luminaire are subject to national safety regulations. The manufacturer is then discharged from liability when damage is caused by improper use or installation. If any luminaire is subsequently modified, the person responsible for the modification shall be considered as manufacturer.

L'installation et l'entretien ne peuvent être réalisés que par du personnel qualifié. Pour l'installation et l'utilisation du luminaire, les normes de sécurité nationales doivent être respectées. Le fabricant décline toute responsabilité résultant d'une installation ou d'une mise en œuvre inappropriée du produit. Toutes les modifications apportées au luminaire se feront sous la responsabilité exclusive de celui qui les effectuera.

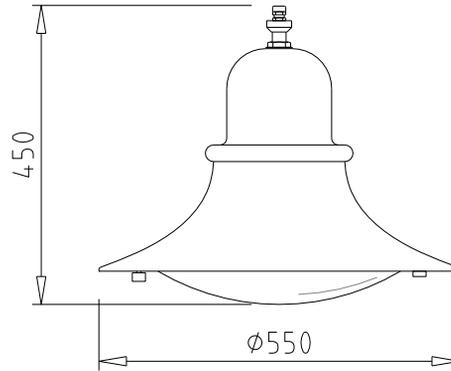
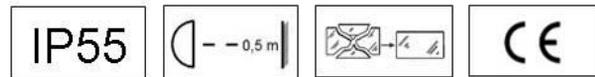

- Nennspannung 230 V~, 50Hz  
-Max. A = 0,093 m<sup>2</sup>

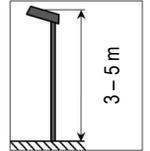

**Lunux Lighting GmbH**

Zaucheweg 4  
04316 Leipzig

Telefon +49 (0)341 241872 0  
Telefax +49 (0)341 241872 38

info@lunux-lighting.com  
www.lunux-lighting.com

DE Die Angaben können je nach Ausführung variieren. Technische Änderungen vorbehalten. Alle Angaben ohne Gewähr.

EN The details may vary depending on the model. Technical changes reserved. No liability assumed for details.

FR Les indications peuvent varier en fonction de l'exécution. Sous réserve de modification technique. Toutes les indications sans engagement.

ES Los datos pueden variar según versión. Reservado el derecho a realizar modificaciones técnicas. Todos los datos son sin garantía.

# I. Montage / Mounting / Installation

1.

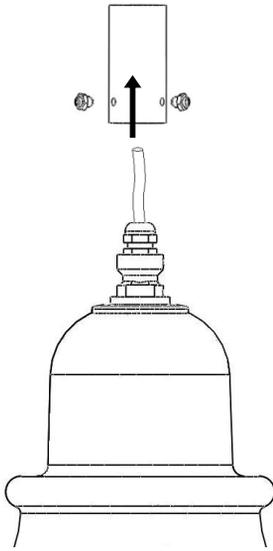

2.

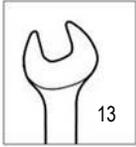
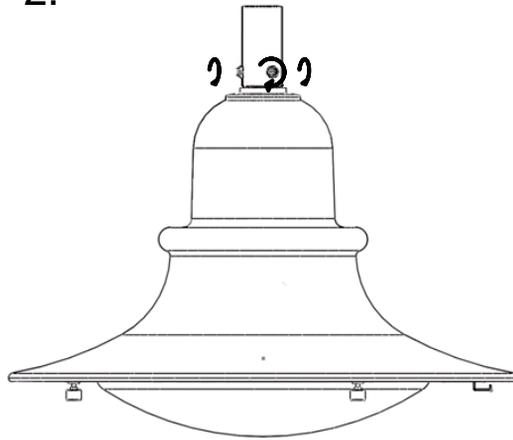

# II. Elektrischer Anschluss / Wiring / Raccordement électrique

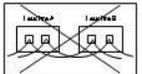
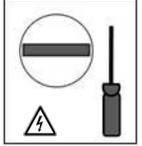

	Easy Basic	Basic	Basic +	Smart	Smart+
		Steuerph. / Lineswitch	Astro	DALI	Zhaga
1 blau / blue	N	N	N	N	N
2 braun / brown	L	L	L	L	L
3 schwarz / black	-	L' (230V=100% / 0V=50%)	-	Da+	-
4 grau / grey	-	-	-	Da-	-
5 grün/gelb   gr/ye	PE	PE	PE	PE	PE

L = 230VAC

L' = 230VAC

L' on = 100% / L' off = 50%

# III. Elektroblok / Electronic unit / Bloc électronique

1.

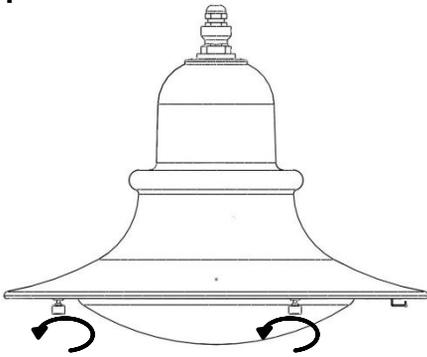

2.

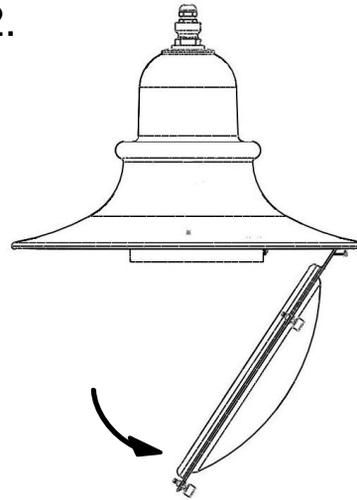

3.

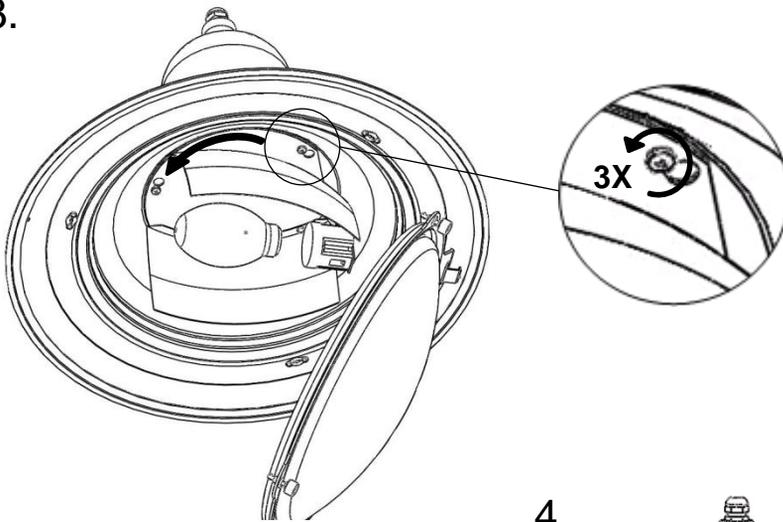

4.

